

# COMPUTER INSTRUCTIONS

## COMPUTER INSTRUCTIONS

MODEL NUMBER: SMT 5.15

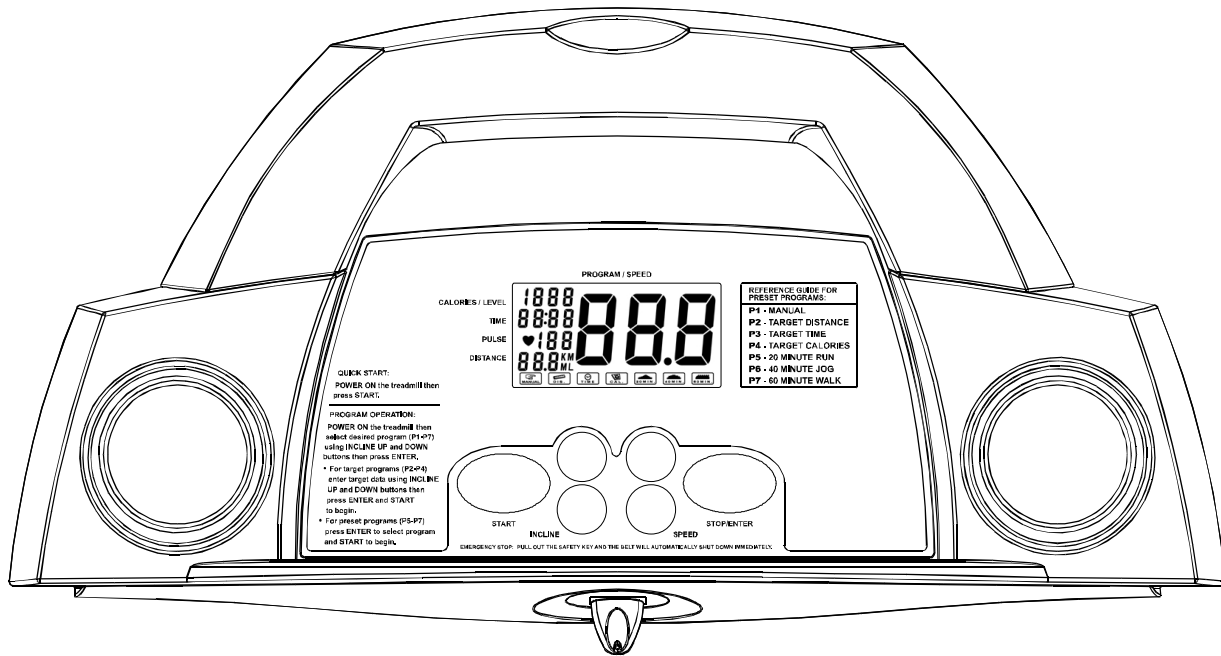

## SMT-5.15 COMPUTER INSTRUCTIONS

## COMPUTER OPERATION

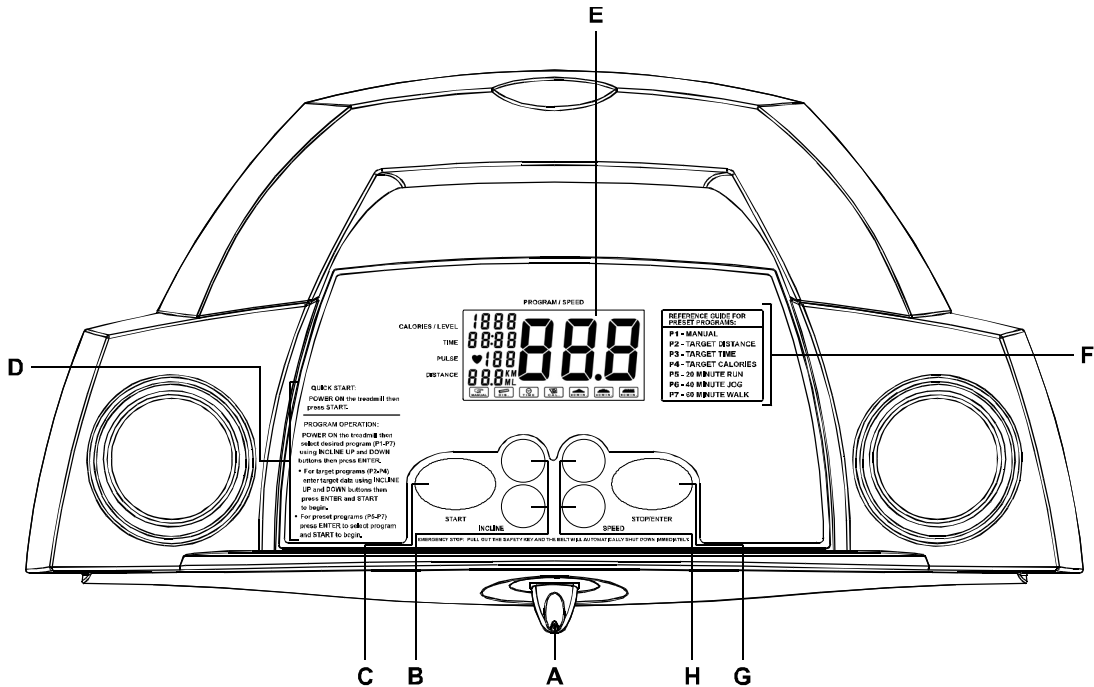

Safety Key	A	B	INCLINE UP/DOWN Buttons
START Button	C	D	Quick Start/Program Operation
LCD Window	E	F	Reference Guide
STOP/ENTER Button	G	H	SPEED UP/DOWN Button

**BUTTONS FUNCTION**

**START** – Press to start exercise at initial speed 0.5MPH / 0.8KPH.

**STOP / ENTER**

- Press to confirm program and preset function values setting mode.
- Press to run setting procedure before pressing the START KEY.
- Press to stop exercise during workout time.

**SPEED UP**

- Press to increase exercise speed by 0.1MPH / KPH.
- Hold the button to increase rapid speed by 0.5MPH / KMPH per second and release the button to stop the function.

**SPEED DOWN**

- Press to decrease exercise speed by 0.1MPH / KPH.
- Hold the button to decrease rapid speed by 0.5MPH / KMPH per second and release the button to stop the function.

**INCLINE UP / DOWN**

- Press up or down to change incline level.
- Press to select programs and preset related function value.

## COMPUTER OPERATION

### **SAFETY KEY**

The safety key must be inserted into the slot on the console in order to operate the treadmill. Always insert the safety key and attach the clip to your clothing at your waist before beginning your workout. If you should encounter problems and need to stop the motor quickly, simply pull on the cord to disengage the safety key from the console. To continue operation first turn the power switch to off and set the speed controller to stop. Next turn the power switch to on and reinsert the safety key into the console.

### **ENGLISH / METRIC CONVERSION**

The treadmill computer display can show METRIC and ENGLISH information. This should be preset for your area by the factory. However, in case that the treadmill needs to be converted between METRIC and ENGLISH readout, please follow the procedure below:

Set the POWER SWITCH to ON. Press the START button on the computer and hold it. Insert the SAFETY KEY then release the START button. The computer will sound one short beep and the LCD will show "ML" (English) as the factory setting. Press INCLINE UP/DOWN button to switch between ML and KM (Metric) and press STOP/ENTER button to confirm the setting. The computer will sound a long beep and will return to the POWER ON mode with the new setting.

### **POWER ON**

Set the POWER SWITCH, located on the base frame, to ON and insert the SAFETY KEY. All LCD figures will light up with a short beep sound then display "0" except the SPEED, which will show "P1" and be blinking. The bottom program indication shows the MANUAL PROGRAM image. If there is no further operation to the computer for 3 minutes, the LCD will go off automatically. Press any button to return to the POWER ON mode.

### **QUICK START**

When the treadmill is in POWER ON status, press the START button to activate the QUICK START program. The speed LCD will count down 3 seconds with 3 short beep sounds then start from 0.5MPH/0.8KPH. Press the SPEED UP/DOWN button to change the speed. Press the INCLINE UP/DOWN button to elevate the treadmill. The TIME, CALORIES and DISTANCE will count up from 0.

### **COMPUTER OPERATION:**

After turning on the power the computer will show a full display for 2 seconds. The "P1" (manual program) will then begin blinking in the upper right corner of the LCD window. Press the INCLINE UP / DOWN buttons to select the desired program. Press the STOP/ENTER button to confirm the selected program then press the START button to start the program. Please refer to the following instructions for the different program options.

### **PAUSE/STOP**

During the workout, press the STOP/ENTER button once to pause the treadmill. Press the STOP/ENTER button twice to delete all the workout data and return to POWER ON status.

### **PROGRAM 1 – MANUAL/QUICK START**

Press the INCLINE UP / DOWN button to select the program "P1", then press the STOP/ENTER button to select the program and then press the START key to start exercising. The speed will start from 0.5 MPH / 0.8 KPH. The incline will start from level 0. Press the SPEED UP/DOWN BUTTON to adjust the speed and press the INCLINE UP/DOWN button to adjust the incline level. Time, Distance and Calories all count up from 0.

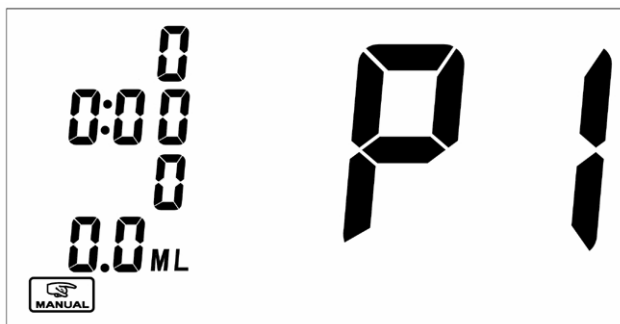

## COMPUTER OPERATION

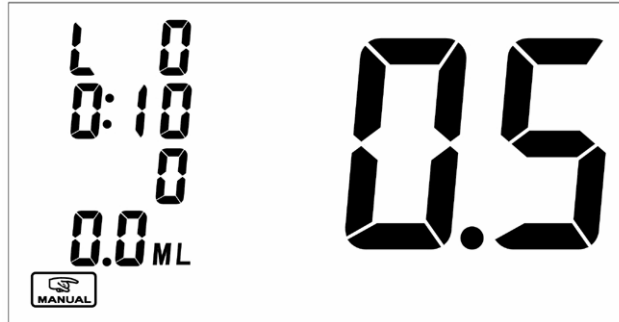
**PROGRAM 2 – TARGET DISTANCE**

Press the INCLINE UP/DOWN button until the LCD shows P2 and is blinking. The bottom program indication shows the DISTANCE PROGRAM image. Press the STOP/ENTER button to select the program. The DISTANCE digits will show 0.0 and be blinking. Press the INCLINE UP/DOWN button to adjust the target distance and press the STOP/ENTER button to confirm the target distance. Press the START button to start the program. The speed will start from 2.0 MPH / 3.2 KPH and the incline will start from level 0. Press the SPEED UP/DOWN button to adjust the speed and press the INCLINE UP/DOWN button to adjust the incline level. Time and Calories will count up from 0 and the distance will count down from the target distance.

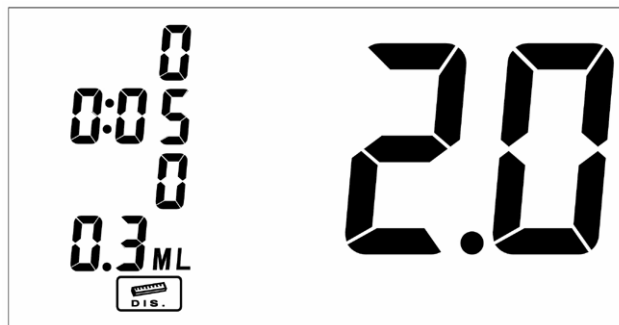
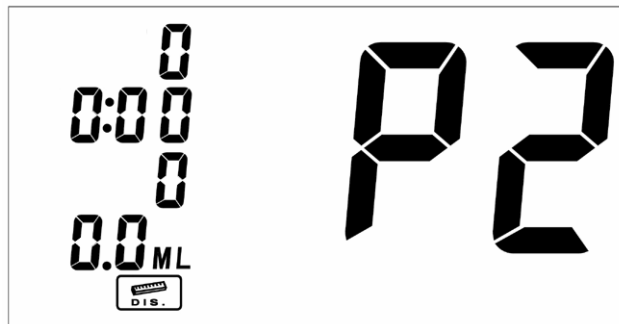

COMPUTER OPERATION**PROGRAM 3 – TARGET TIME**

Press the INCLINE UP/DOWN button until the LCD shows P3 and is blinking. The bottom program indication will show the TIME PROGRAM image. Press the STOP/ENTER button to select the program. The TIME display digits will show 0:00 and be blinking. Press the INCLINE UP/DOWN button to adjust the target workout time and press the STOP/ENTER button to confirm the target workout time. Press the START button to start the program. The Speed will start from 2.0 MPH / 3.2 KPH and the Incline will start from level 0. Press the SPEED UP/DOWN button to adjust the speed and press the INCLINE UP/DOWN button to adjust the incline level. The Distance and Calories will count up from 0 and the Time will count down from the target workout time.

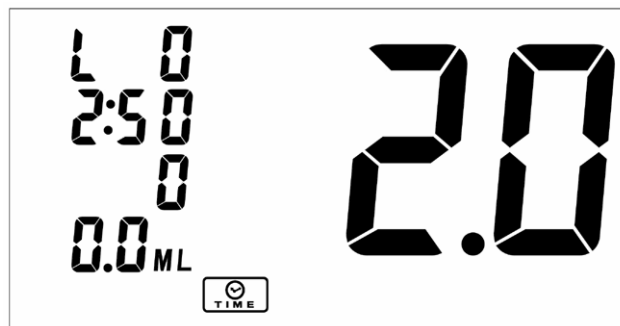
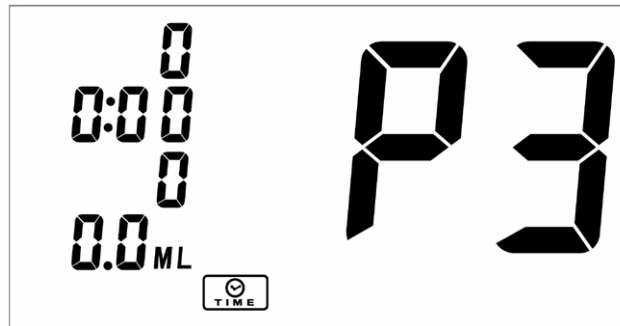
**PROGRAM 4 – TARGET CALORIES**

Press the INCLINE UP/DOWN button until the LCD shows P4 and is blinking. The bottom program indication will show the CALORIES PROGRAM image. Press the STOP/ENTER button to select the program. The CALORIES display digits will show 0 and be blinking. Press the INCLINE UP/DOWN button to adjust the target calories burned and press the STOP/ENTER button to confirm the target calories burned. Press the START button to start the program. The Speed will start from 2.0 MPH / 3.2 KPH and the Incline will start from level 0. Press the SPEED UP/DOWN button to adjust the speed and press the INCLINE UP/DOWN button to adjust the incline level. The Distance and Time will count up from 0 and the Calories will count down from the target workout time.

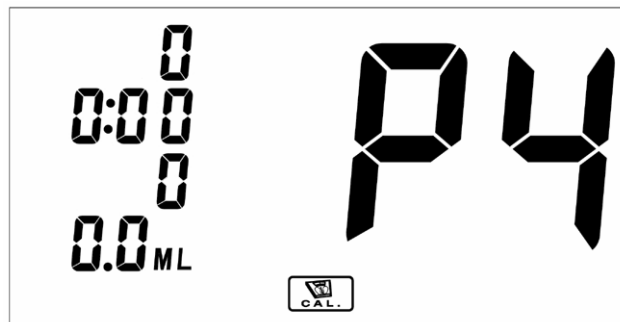

## COMPUTER OPERATION

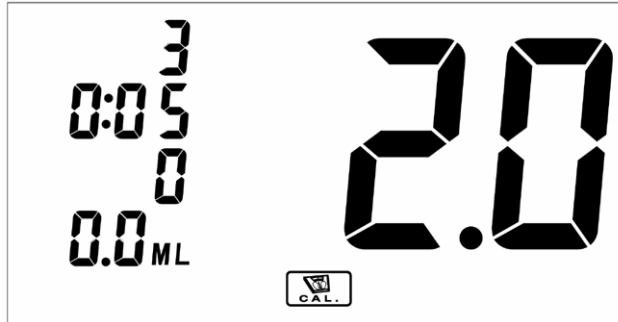

## PROGRAM 5 – 20 MINUTES RUNNING PROGRAM

Press the INCLINE UP/DOWN button until the LCD shows P5 and is blinking. The bottom program indication will show the 20 MIN. PROGRAM image. Press the STOP/ENTER button to select the program. Press the START button to start the program. The Speed will start from 2.0 MPH/3.2 KPH and the incline will start from level 0. Press the SPEED UP/DOWN button during the workout if you want to overwrite the preset speed program. Press the INCLINE UP/DOWN button to adjust the incline level. The TIME will count down from 20 minutes and DISTANCE and CALORIES will count up from 0.

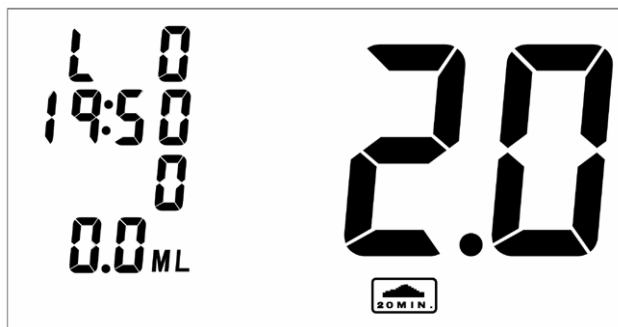
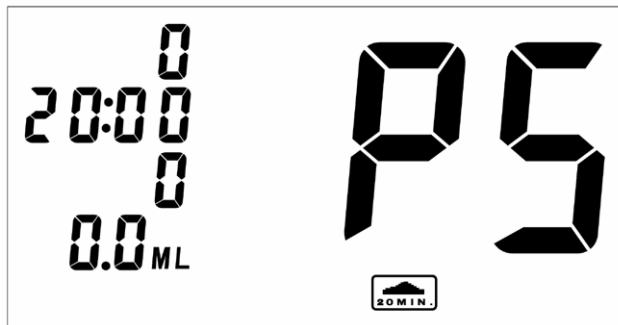

COMPUTER OPERATION**SPEED CHART**

TIME	SPEED	
	MPH	KPH
20-18	2	3.2
18-15	5	8
15-12	5.6	9
12-9	6.3	10
9-6	6.9	11
6-3	7.5	12
3-1	8.1	13
1-0	2	3.2

**PROGRAM 6 – 40 MINUTES JOGGING PROGRAM**

Press the INCLINE UP/DOWN button until the LCD shows P6 and is blinking. The bottom program indication will show the 40 MIN. PROGRAM image. Press the STOP/ENTER button to select the program. Press the START button to start the program. The Speed will start from 1.9 MPH/3.0 KPH and the incline will start from level 0. Press the SPEED UP/DOWN button during the workout if you want to overwrite the preset speed program. Press the INCLINE UP/DOWN button to adjust the incline level. The TIME will count down from 40 minutes and the DISTANCE and CALORIES will count up from 0.

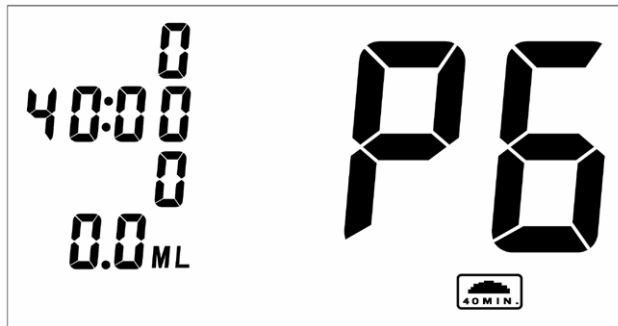
**SPEED CHART**

TIME	SPEED	
	MPH	KPH
40-37	1.9	3
37-34	2.5	4
34-31	3.1	5
31-28	3.8	6
28-24	4.4	7
24-16	5	8
16-4	5.6	9
4-2	6.3	10
2-0	1.9	3

COMPUTER OPERATION**PROGRAM 7 – 60 MINUTES WALK PROGRAM**

Press the INCLINE UP/DOWN button until the LCD shows P7 and is blinking. The bottom program indication will show the 60 MIN. PROGRAM image. Press the STOP/ENTER button to select the program. Press the START button to start the program. The Speed will start from 1.9 MPH/3.0 KPH and the Incline will start from level 0. Press the SPEED UP/DOWN button during the workout if you want to overwrite the preset speed program. Press the INCLINE UP/DOWN button to adjust the incline level. The TIME will count down from 60 minutes and the DISTANCE and CALORIES will count up from 0.

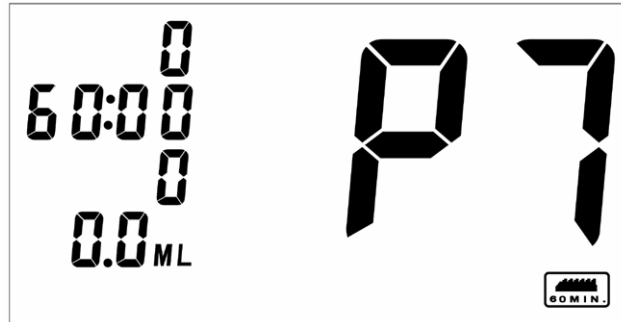
**SPEED CHART**

TIME	SPEED	
	MPH	KPH
60-57	1.9	3
57-54	2.5	4
54-51	3.1	5
51-48	3.8	6
48-45	4.4	7
45-24	5	8
24-21	4.4	7
21-2	3.8	6
2-0	1.9	3

