

USER'S MANUAL

6.25 MOTORIZED TREADMILL

MODEL NUMBER: 6.25

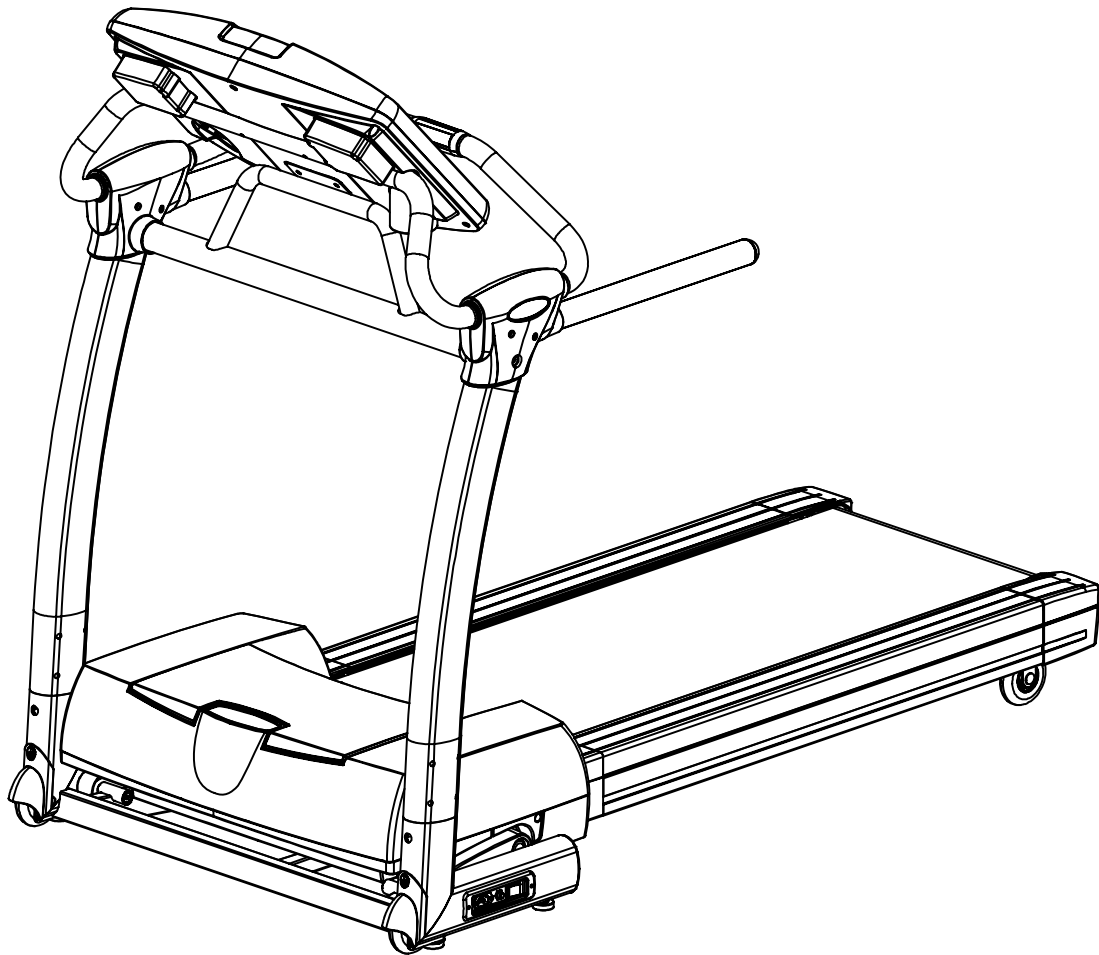

USER WEIGHT LIMITATION: **350lbs.**

SERIAL NUMBER (found on frame):



PRECAUTIONS

Precautions:

WARNING: To reduce the risk of burns, fire, electric shock, or injury to persons, read the following important precautions and information before operating the treadmill. It is the responsibility of the owner to ensure that all users of this treadmill are adequately informed of all warnings and precautions.

- Use the treadmill only as described in this manual.
- Place on a level surface, with 2 meters (6 feet) of clearance behind it. Do not place the treadmill on any surface that blocks air openings. To protect the floor or carpet from damage, place a mat under the treadmill.
- When choosing a location for the treadmill make sure that the location and position permit access to a plug.
- Keep the treadmill indoors, away from moisture and dust. Do not put the treadmill in a garage or covered patio, or near water.
- Do not operate the treadmill where aerosol products are used or where oxygen is being administered.
- Keep children under the age of 12 and pets away from the treadmill at all times.
- The treadmill should not be used by persons weighing more than 350lbs.
- Never allow more than one person on the treadmill at a time. Wear appropriate exercise clothing when using the treadmill. Do not wear loose clothing that could become caught in the treadmill. Athletic support clothes are recommended for both men and women. Always wear athletic shoes. Never use the treadmill with bare feet, wearing only stockings, or in sandals.
- When connecting the power cord, plug the power cord into a grounded circuit. No other appliance should be on the same circuit.
- Always straddle the belt and allow it to start moving before stepping onto the belt.
- Always examine your treadmill before using to ensure all parts are in working order.
- Allow the belt to fully stop before dismounting.
- Never insert any object or body parts into any opening.
- Follow the safety information in regards to plugging in your treadmill.
- Keep the power cord away from the incline wheels and do not run the power cord underneath your treadmill. Do not operate the treadmill with a damaged or frayed power cord.
- Always unplug the treadmill before cleaning and/or servicing. Service to your treadmill should only be performed by an authorized service representative, unless authorized and/or instructed by the manufacturer. Failure to follow these instructions will void the treadmill warranty.
- Never leave the treadmill unattended while it is running.

POWER REQUIREMENTS**Power Requirements:**

IMPROPER CONNECTION OF THE EQUIPMENT GROUNDING CONNECTOR CAN RESULT IN A RISK OF AN ELECTRIC SHOCK. CHECK WITH A QUALIFIED ELECTRICIAN OR SERVICE MAN IF YOU ARE IN DOUBT AS TO WHETHER THE PRODUCT IS PROPERLY GROUNDED. DO NOT MODIFY THE PLUG PROVIDED WITH THE PRODUCT, IF IT WILL NOT FIT THE OUTLET; HAVE A PROPER OUTLET INSTALLED BY A QUALIFIED ELECTRICIAN.

This treadmill can be seriously damaged by sudden voltage changes in your home's electrical power. Voltage spikes, surges and noise interference can result from weather conditions or from other appliances being turned on or off. To reduce the possibility of treadmill damage, always use a surge protector (not included) with your treadmill.

Surge protectors can be purchased at most hardware stores. The manufacturer recommends a single outlet surge protector with a UL 1449 rating as a Transient Voltage Surge Suppressor (TVSS) with a UL suppressed voltage rating of 400V or less and an electrical rating 120VAC, 15 amps.

This treadmill must be grounded to reduce the risk of electrical shock. Grounding provides a path of least resistance for electric current, should the treadmill malfunction. This treadmill comes with an electrical cord having an equipment-grounding conductor and a grounding plug. Always plug the power cord into a surge protector, and plug the surge protector into an appropriate outlet that is properly installed and grounded in accordance with all local codes and ordinances.

This product is for use on a nominal 120-volt circuit, and has a grounding plug that looks like the plug illustrated in the drawing below.

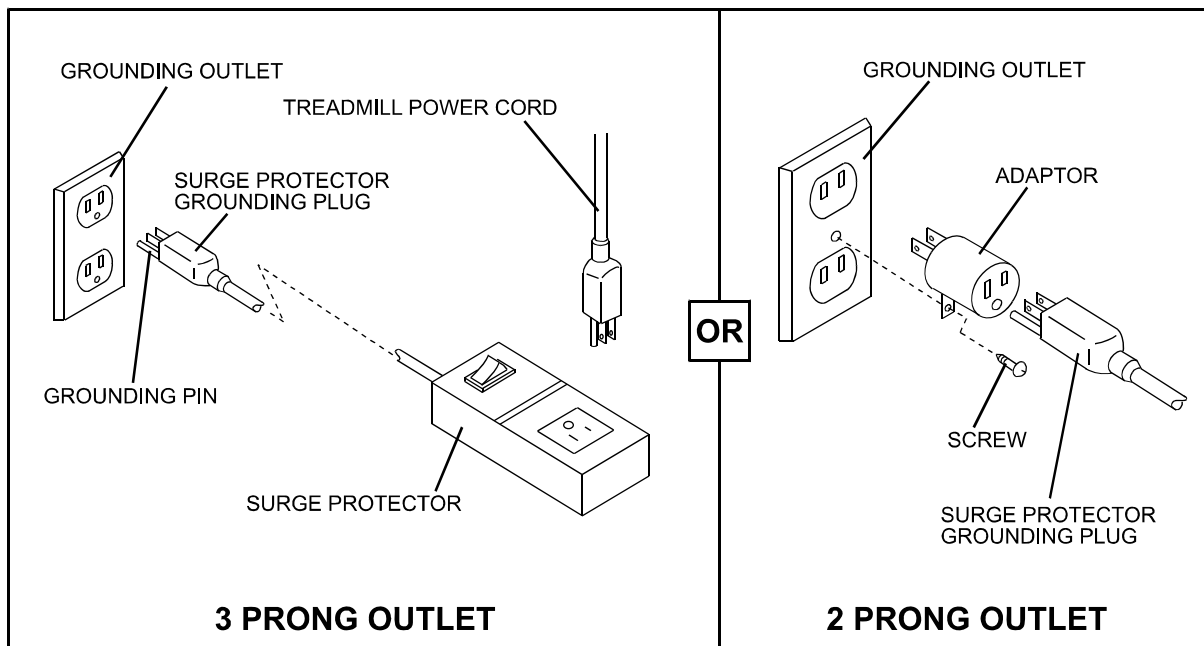

PREASSEMBLY

Open the boxes:

You are now ready to open the boxes of your new equipment. Make sure to inventory all of the parts that are included in the boxes. Check the Hardware Comparison Chart for a full count of the number of parts included for this product to be assembled properly. If you are missing any parts or have any assembly questions call the manufacturer.

Gather your tools:

Before starting the assembly of your unit, make sure that you have gathered all the necessary tools you may require to assemble the unit properly. Having all of the necessary equipment at hand will save time and make the assembly quick and hassle-free.

Clear your work area:

Make sure that you have cleared away a large enough space to properly assemble the unit. Make sure the space is free from anything that may cause injury during assembly. After the unit is fully assembled, make sure there is a comfortable amount of free area around the unit for unobstructed operation.

Invite a friend:

Some of the assembly steps may require heavy lifting. It is recommended that you obtain the assistance of another person when assembling this product.

User Weight Limitation:

Please note that there is a weight limitation for this product. **If you weigh more than 136kgs (300lbs.) it is not recommended that you use this product. Serious injury may occur if the user's weight exceeds the limit shown here.** This product is not intended to support users whose weight exceeds this limit.

HARDWARE COMPARISON CHART

Hardware chart:

For your convenience, we have identified the hardware used in the assembly of this product. This chart is provided to help you identify those items that may be unfamiliar to you.

NO.	DESCRIPTION	QTY.
4	M6 x 16mm Screw	2
15	4 x 19mm Screw	8
56	M8 x 25mm Bolt	4
103	M8 x 110mm Bolt	2
104	8 x 14mm Washer	2
116	M6 x 15mm Bolt	2
A	5mm Allen Wrench	1
B	Phillips Head Wrench	1
C	4mm Allen Key	1
D	5mm Allen Key	1
E	8mm Allen Key	1

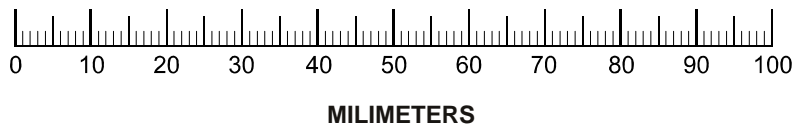
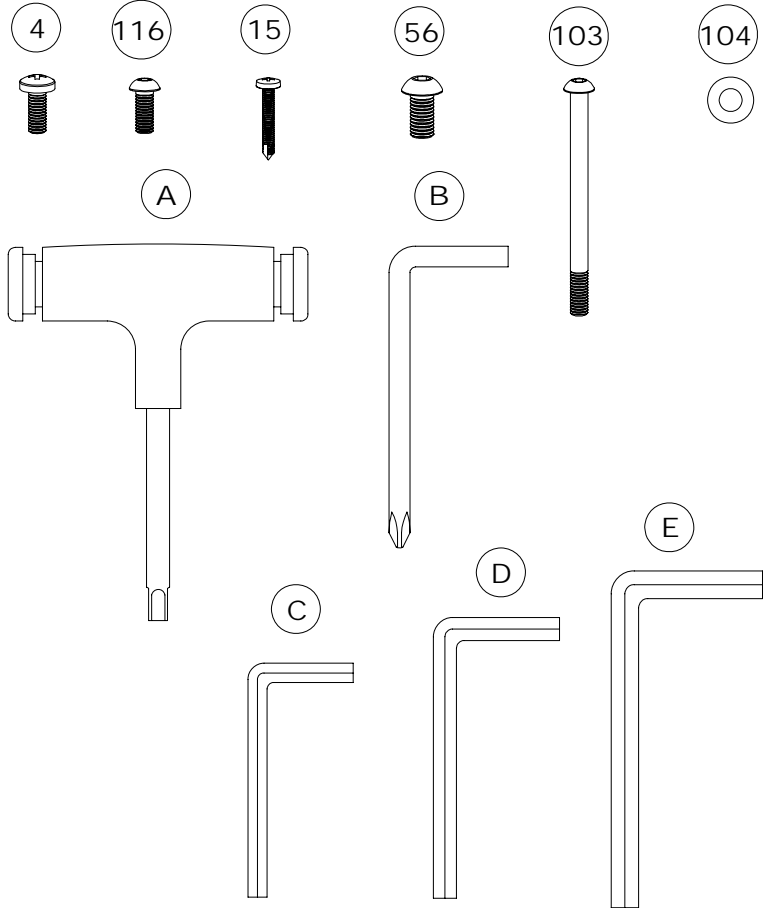

SMOOTH 6.25 MOTORIZED TREADMILL

PARTS LIST

NO.	DESCRIPTION	QTY.	ORDER NO.	NO.	DESCRIPTION	QTY.	ORDER NO.
1	COMPUTER INSERT	1	6.25-01	29	POWER PLATE	1	6.256.25-29
2	EKG PULSE SENSOR	2	6.25-02	30	M5 X 12MM SCREW	1	6.25-30
3	FRONT HANDLE BAR FOAM GRIP	2	6.25-03	31	WASHER	1	6.25-31
4	M8 X 16MM ALLEN BOLT	6	6.25-04	32	FOOT LOCKER	1	6.25-32
5	M6 X 55MM ALLEN BOLT	4	6.25-05	33	FOOT LOCKER SPRING	1	6.25-33
6	FRONT HANDLEBAR	1	6.25-06	34	BASE FRAME END CAP	2	6.25-34
7	COMPUTER WIRE - UPPER SECTION	1	6.25-07	35	LEVEL ADJUSTER	4	6.25-35
8	SAFETY KEY	1	6.25-08	36	BASE FRAME	1	6.25-36
9	HANDLE BAR	2	6.25-09	37	FOLD UP SUPPORT BUSHING	2	6.25-37
10	HANDLE BAR FOAM GRIP	2	6.25-10	38	PLASTIC INSERT	1	6.25-38
11	HANDLE BAR END CAP	2	6.25-11	39	3/8" X 30 ALLEN BOLT	1	6.25-39
12	CONSOLE SUPPORT TUBE	1	6.25-12	40	BUSHING	1	6.25-40
13	LEFT UPRIGHT	1	6.25-13	41	FOLD UP SUPPORT WHEEL	1	6.25-41
14	RIGHT UPRIGHT	1	6.25-14	42	FOLD UP SUPPORT	1	6.25-42
15	M4 X 15 DRILL HEAD SCREW	34	6.25-15	43	SHOCK	1	6.25-43
16	CROSS BRACE	1	6.25-16	44	C CLIP	2	6.25-44
17	HANDLE BAR COVER - LEFT #1	1	6.25-17	45	RUBBER CUSHION	2	6.25-45
18	HANDLE BAR COVER - LEFT #2	1	6.25-18	46	RUNNING BELT	1	6.25-46
19	HANDLE BAR COVER - RIGHT #1	1	6.25-19	47	M8 X 25MM DECK SCREW	8	6.25-47
20	HANDLE BAR COVER - RIGHT #2	1	6.25-20	48	RUNNING DECK	1	6.25-48
21	PLASTIC COVER FIXING INSERT	12	6.25-21	49	MOTOR HOOD PAD	1	6.25-49
22	TRANSPORT WHEEL COVER	2	6.25-22	50	MOTOR HOOD	1	6.25-50
23	M10 X 35 MM TRANSPORT WHEEL BOLT	2	6.25-23	51	MOTOR BOTTOM COVER	1	6.25-51
24	7 PINS CONTROL WIRE - LOWER SECTION	1	6.25-24	52	SAFETY KEY WIRE - LOWER SECTION	1	6.25-52
25	TRANSPORTATION WHEEL	4	6.25-25	53	FLAT WASHER	2	6.25-53
26	M10 NYLON NUT	4	6.25-26	54	RUBBER CUSHION	1	6.25-54
27	M14 X 90MM BOLT	2	6.25-27	55	M8 X 85MM BOLT	1	6.25-55
28	M5 X 12MM POWER PLATE SCREW	2	6.25-28	56	M8 X 25MM ALLEN BOLT	8	6.25-56

SMOOTH 6.25 MOTORIZED TREADMILL

PARTS LIST

NO.	DESCRIPTION	QTY.	ORDER NO.	NO.	DESCRIPTION	QTY.	ORDER NO.
57	M10 X 136MM BOLT	1	6.25-57	86	REAR ROLLER SHAFT	1	6.25-86
58	MOTOR HOLDER	1	6.25-58	87	M6 X 70 ALLEN BOLT	3	6.25-87
59	DRIVING MOTOR	1	6.25-59	88	SIDE RAIL END CAP - LEFT	1	6.25-88
60	ELEVATION MOTOR	1	6.25-60	89	SIDE RAIL END CAP - RIGHT	1	6.25-89
61	ELEVATION GEAR SLEEVE	1	6.25-61	90	M8 NYLON NUT	4	6.25-90
62	4 X 12 WASHER	10	6.25-62	91	M8 X 43MM BOLT	2	6.25-91
63	#8 X 25 SCREW	10	6.25-63	92	ELEVATION SUPPORT CAP	2	6.25-92
64	ANTISLIPPING RUBBER PIECE	6	6.25-64	93	ELEVATION SUPPORT TUBE COVER - LEFT	1	6.25-93
65	SIDE RAIL - LEFT	1	6.25-65	94	M10 X 63MM BOLT	1	6.25-94
66	RUNNING DECK SUPPORT TUBE	1	6.25-66	95	M10 X 90MM BOLT	1	6.25-95
67	DECK FRAME SIDE COVER - LEFT	1	6.25-67	96	ELEVATION SUPPORT TUBE	1	6.25-96
68	MOTOR CONTROL BOARD	1	6.25-68	97	ELEVATION SUPPORT TUBE COVER - RIGHT	1	6.25-97
69	ELEVATION CONTROL BOARD	1	6.25-69	98	PLASTIC CLAMP - BOTTOM	2	6.25-98
70	M10 X 35MM BOLT	1	6.25-70	99	CONSOLE SUPPORT FIXING PLATE	2	6.25-99
71	DECK FRAME	1	6.25-71	100	BASE FRAME ROUND ENDCAP	2	6.25-100
72	6 X 13 WASHER	3	6.25-72	101	M8X40BOLT	1	6.25-101
73	FRONT ROLLER	1	6.25-73	102	REAR TRANSPORTATION WHEEL	1	6.25-102
74	FRONT ROLLER SHAFT	1	6.25-74	103	M8 X 80MM ALLEN BOLT	2	6.25-103
75	DRIVING BELT	1	6.25-75	104	8MM WASHER	2	6.25-104
76	DECK RUBBER CUSHION	2	6.25-76	105	BOLT	2	6.25-105
77	SIDE RAIL - RIGHT	1	6.25-77	106	CONSOLE HOUSING - UPPER	1	6.25-106
78	SAFETY KEY WIRE - UPPER SECTION	1	6.25-78	107	CONSOLE HOUSING - BOTTOM	1	6.25-107
79	PLASTIC BUSHING	2	6.25-79	108	WATER BOTTLE HOLDER	2	6.25-108
80	10MM SHAFT	1	6.25-80	109	GLOVE COMPARTMENT FRAME	2	6.25-109
81	DECK FRAME SIDE COVER - RIGHT	1	6.25-81	110	GLOVE COMPARTMENT COVER	2	6.25-110
82	PLASTIC CLAMP - TOP	2	6.25-82	111	HARDWARE PACK (not shown on exploded diagram)	1	6.25-111
83	ELEVATION SUPPORT	2	6.25-83	112	SPRING	1	6.25-112
84	DECK FRAME - REAR	1	6.25-84	113	FOLD UP SENSOR	1	6.25-113
85	REAR ROLLER	1	6.25-85	114	TRANSPORTATION WHEEL BRACKET	1	6.25-114
				115	TRANSPORTATION WHEEL BRACKET PIVOT	1	6.25-115
				116	M6 X15MM Bolt	2	6.25-116

SMOOTH 6.25 MOTORIZED TREADMILL

PARTS DIAGRAM

A MAJORITY OF THE PARTS SHOWN HERE HAVE BEEN PREASSEMBLED AT THE FACTORY.

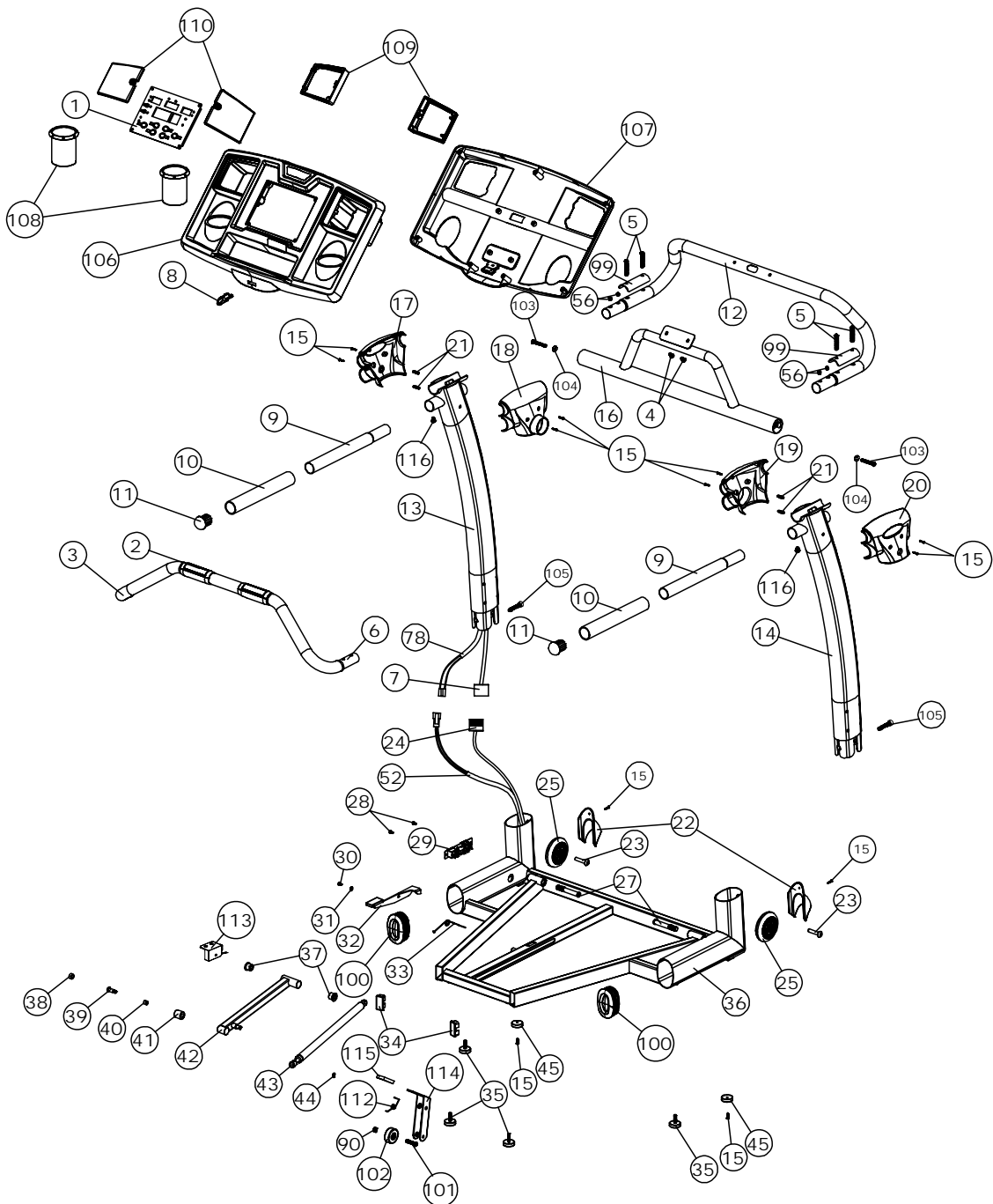

PARTS DIAGRAM

A MAJORITY OF THE PARTS SHOWN HERE HAVE BEEN PREASSEMBLED AT THE FACTORY.

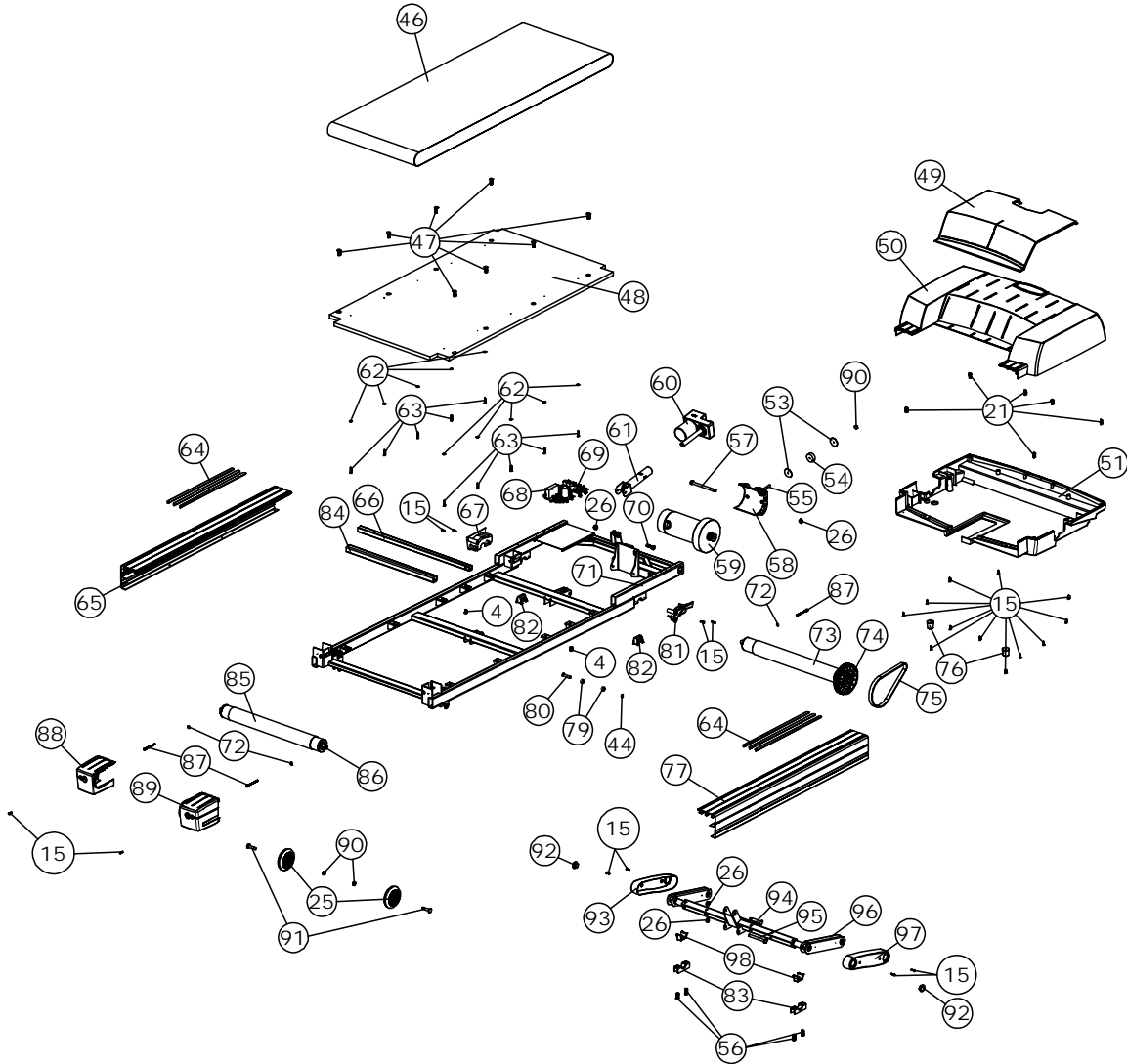

ASSEMBLY**STEP 1:**

Remove your treadmill from the carton and place it on the floor in an open area as shown in FIG 1.

Rotate the Left and Right Uprights (13 and 14) up into position. Connect the Upper Section Computer Wire (7) to the Lower Section 7 Pin Control Wire (24) and the Upper Section Safety Key Wire (78) to the Lower Section Safety Key Wire (52). Insert any extra cable length into the Left Upright (13).

Insert the Left and Right Uprights (13 and 14) into the Base Frame (36) and secure by tightening the two Bolts (105) as shown in FIG 2. The two Bolts (105) are preassembled to the Base Frame (36) at the factory.

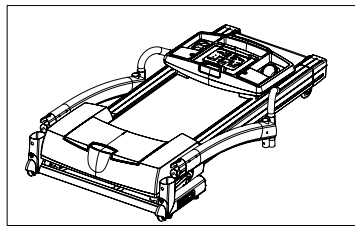
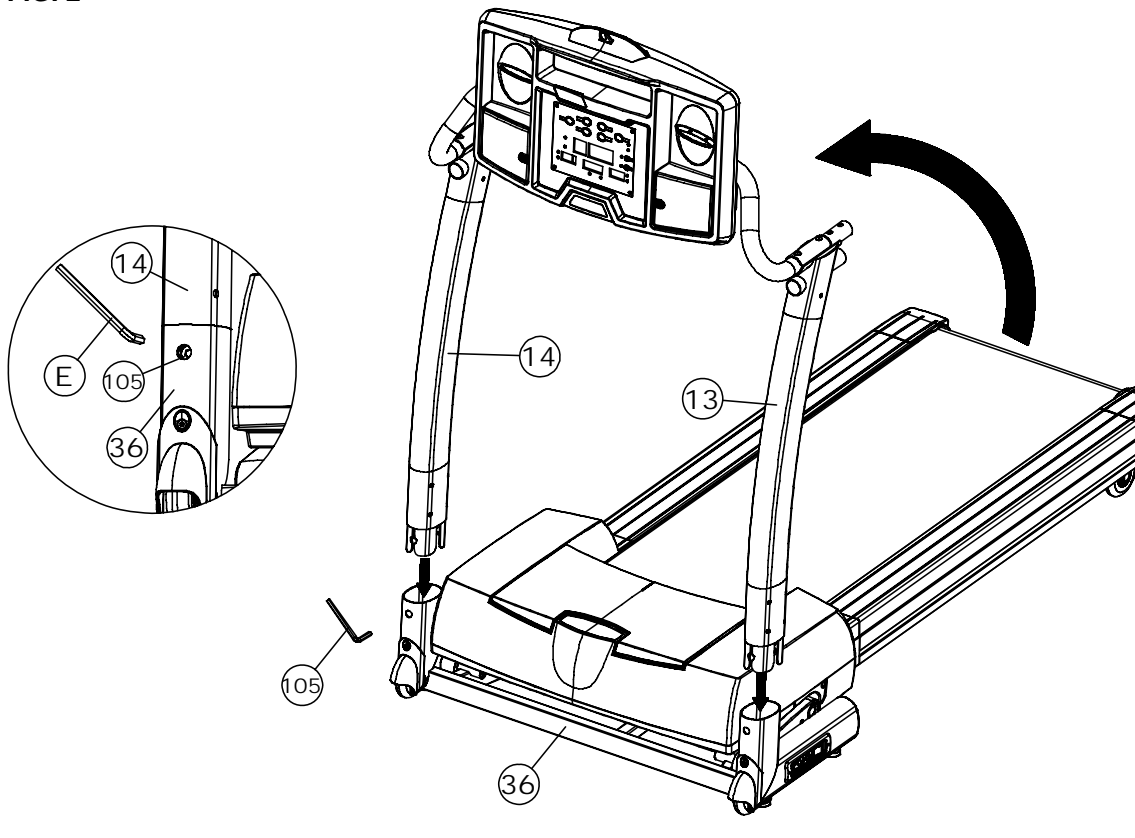
FIG. 1**FIG. 2**

ASSEMBLY**STEP 2:**

Slide the Handlebar Cover – Left #2 (18) and Handlebar Cover – Right #1 (19) onto the Cross Brace (16) as shown.

Attach the Cross Brace (16) to the Left Upright (13) and Right Upright (14) using two 8mm Washer (104) and M8 x 80mm Allen Bolt (103). **Do not fully tighten the M8 x 80mm Allen Bolt (103) at this time.**

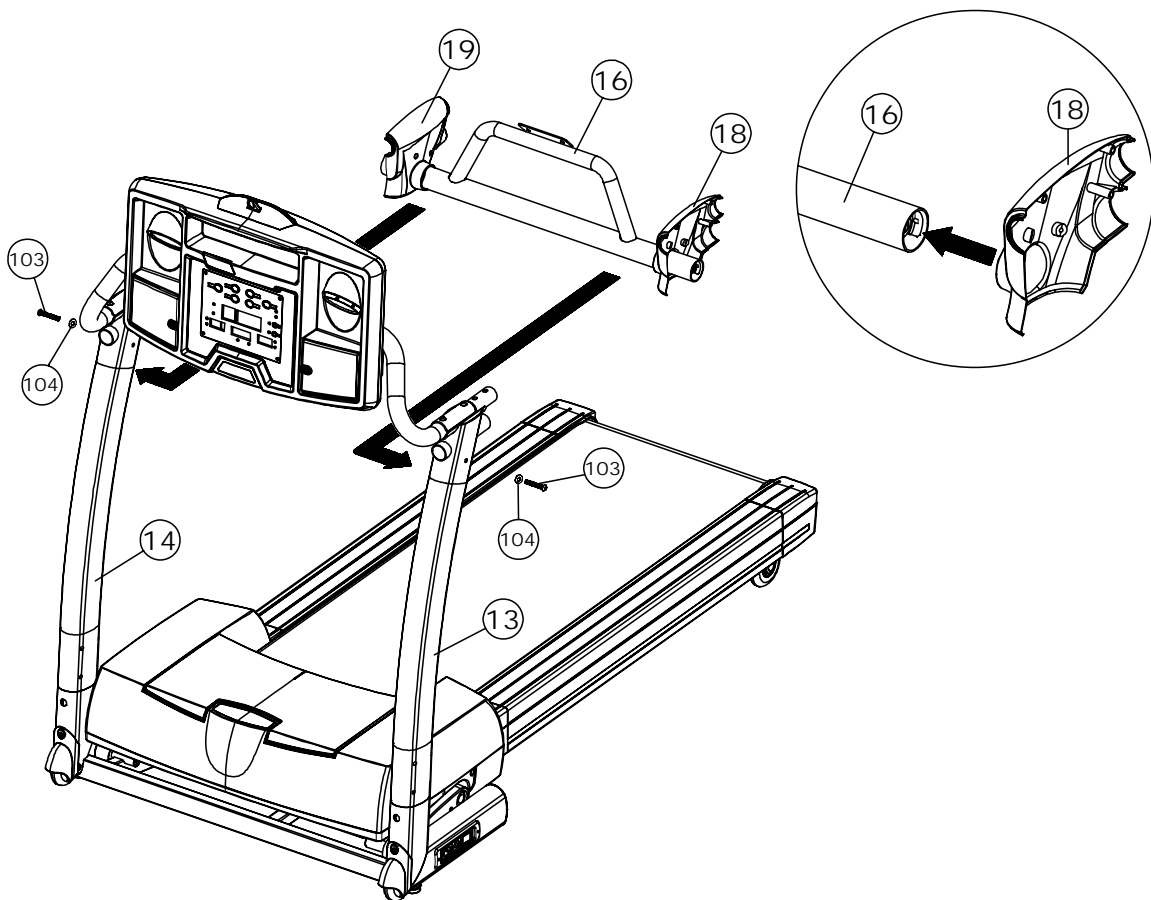

ASSEMBLY**STEP 3:**

Rotate the Console (1) into position as shown and attach it to the Cross Brace (16) using two M8 x 16mm Bolts (4).

Fully tighten the two M8 x 80mm Allen Bolts (103) used in step 2.

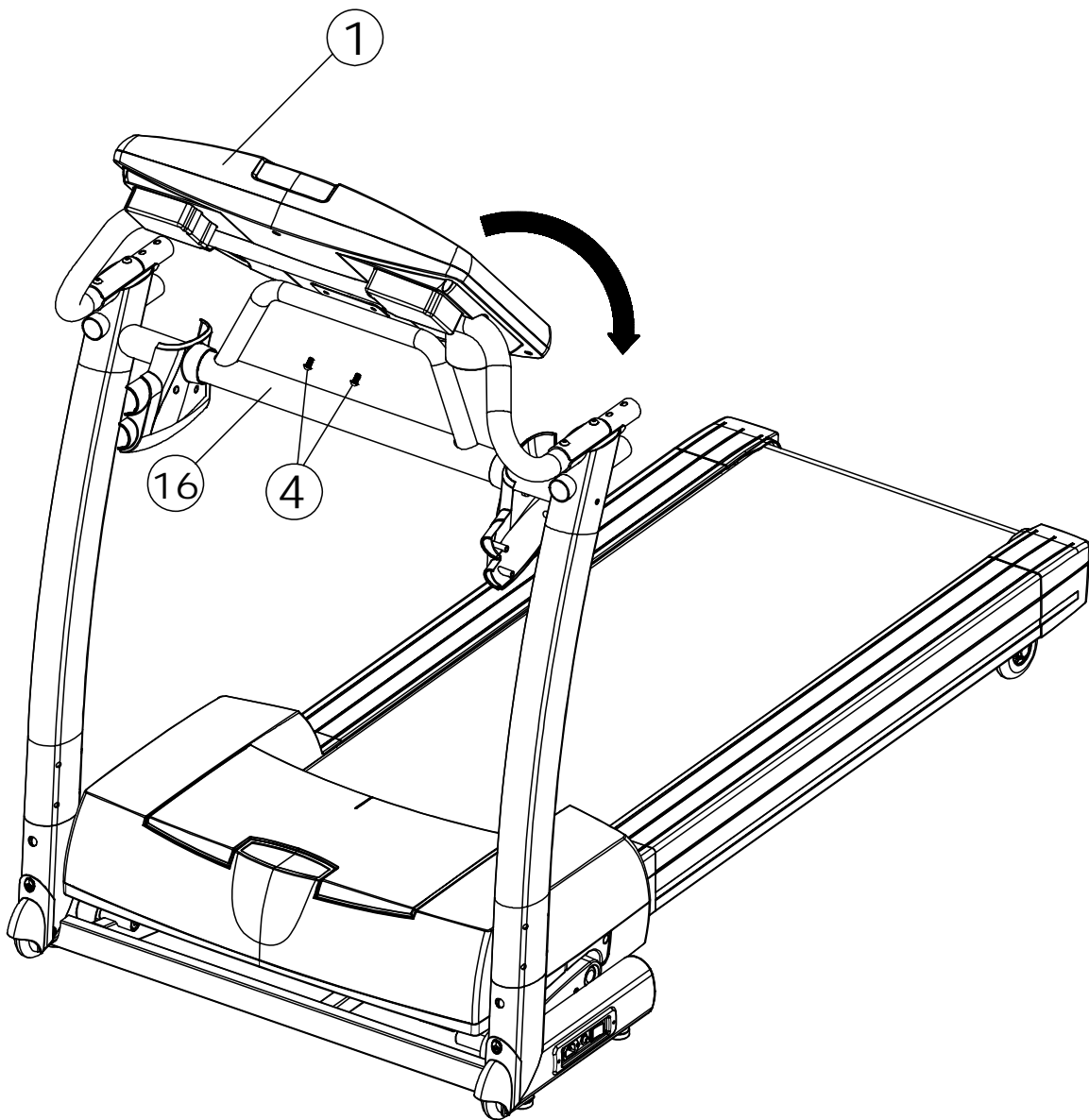

ASSEMBLY**STEP 4:**

Connect the EKG Pulse Sensor (2) wires to the wires from the Console Support Tube (12).

Insert the Front Handlebar (6) into the Console Support Tube (12) and secure using four M8 x 25mm Allen Bolts (56) as shown.

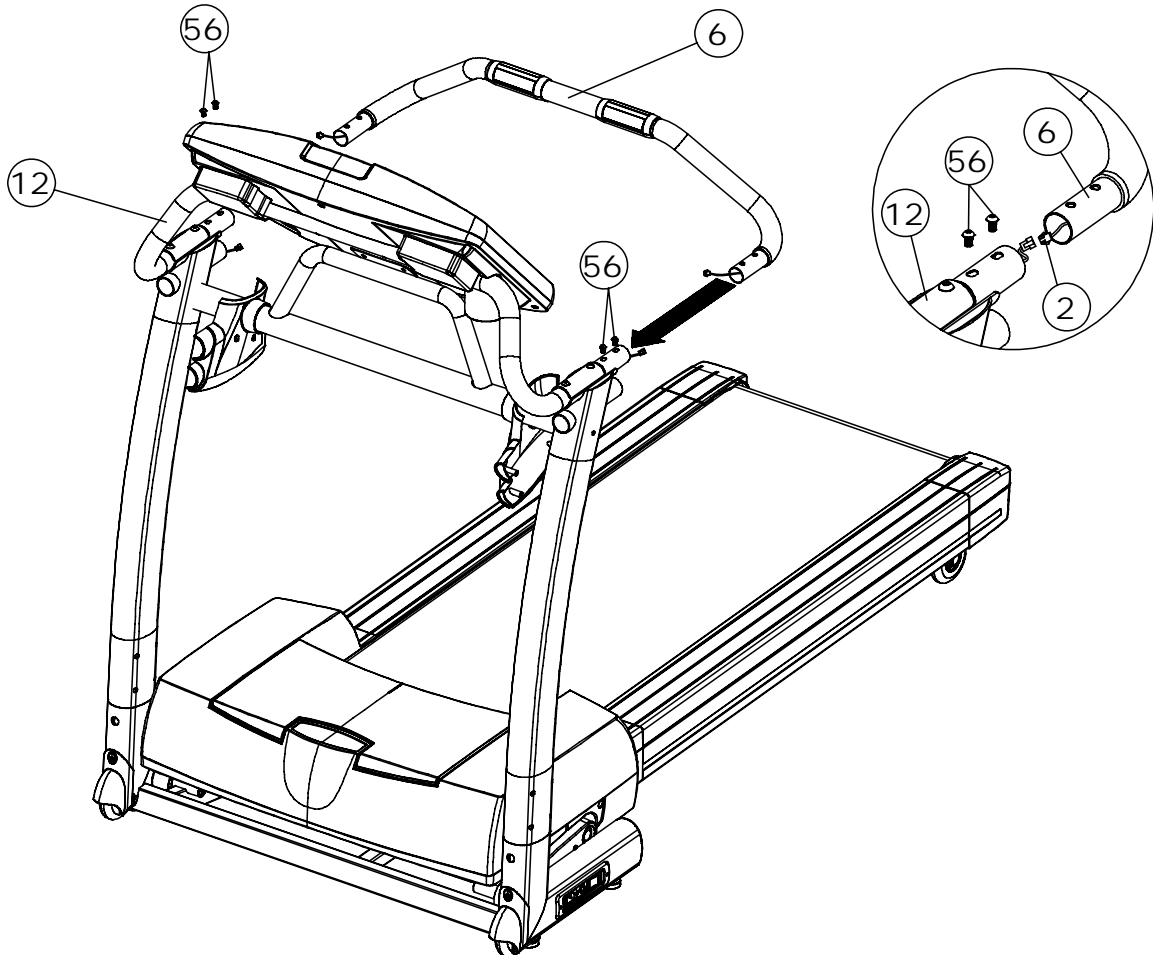

ASSEMBLY**STEP 5:**

Insert the Handlebars (9) into the Left and Right Uprights (13 and 14) and secure using two M6 x 15mm Bolts (116).

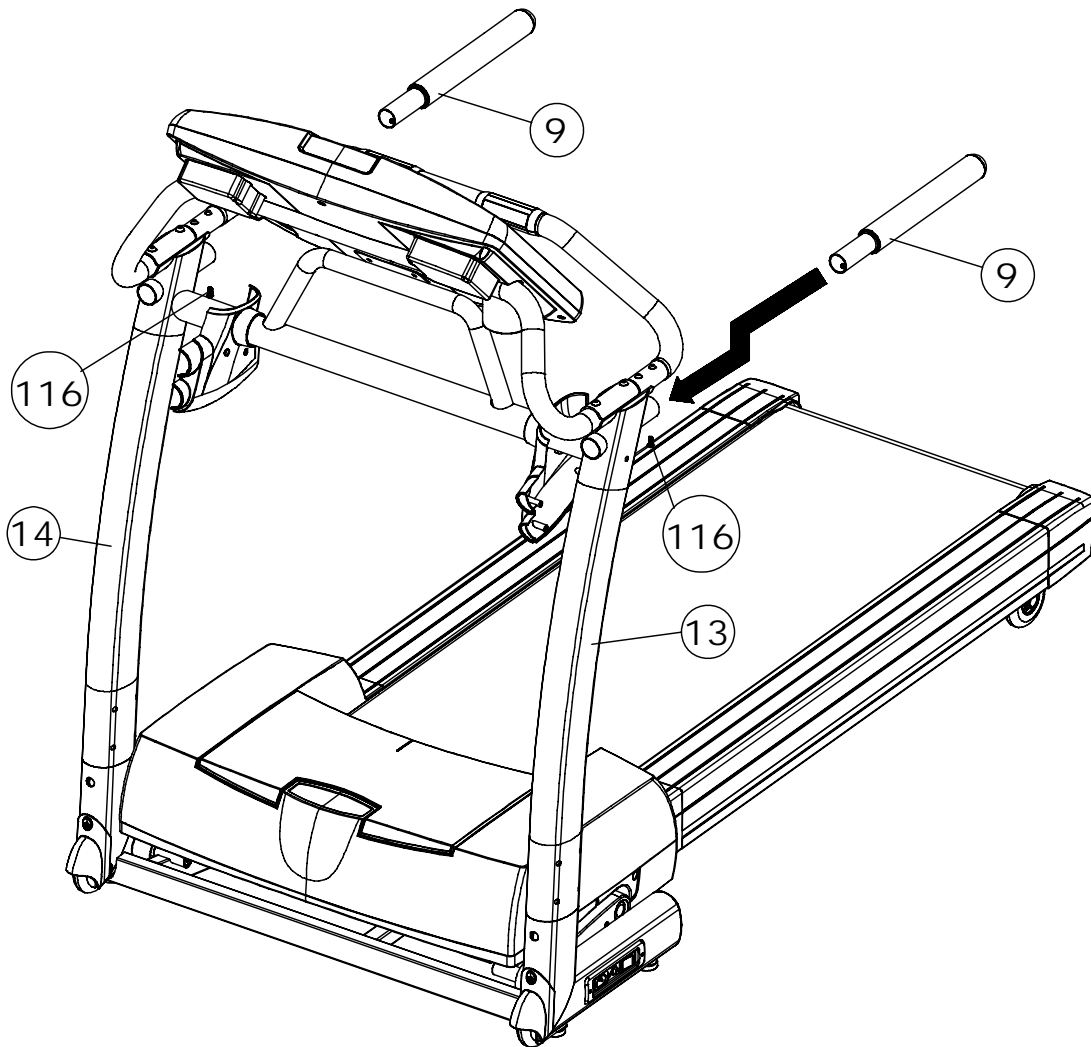

ASSEMBLY**STEP 6:**

Attach the Handlebar Cover – Left #1(17) to the Handlebar Cover – Left #2 (18) using three Plastic Cover Fixing Inserts (21) and four M4 x 15mm Screws (15) as shown.

Attach the Handlebar Cover – Right #1 (20) to the Handlebar Cover – Right #2 (19) using three Plastic Cover Fixing Inserts (21) and four M4 x 15mm Screws (15) as shown.

Your treadmill is now fully assembled.

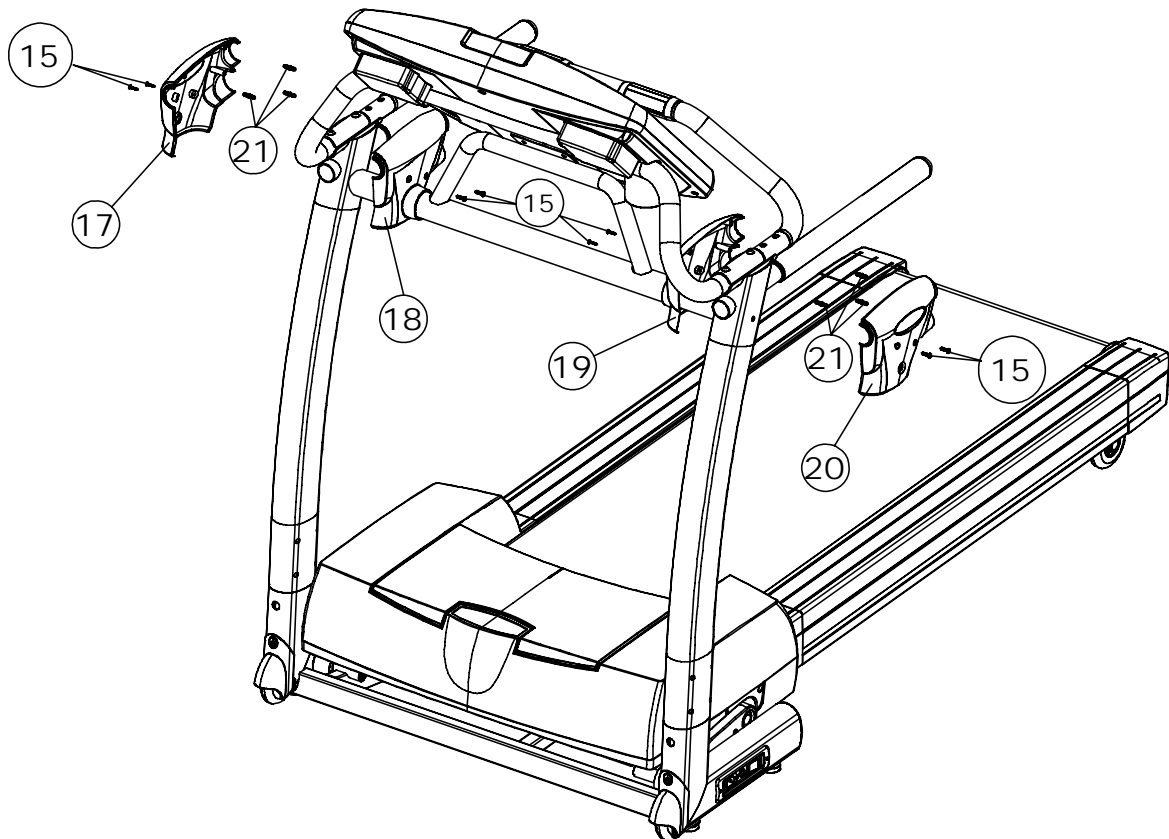

STABILIZER ADJUSTMENT

How to level the treadmill:

An uneven floor or improper stabilizer level can cause the treadmill to wobble during use as well as the incline adjustment to function incorrectly. Please follow the procedure described below to make sure the treadmill stabilizer is adjusted correctly prior to use. You may need the assistance of another person to perform this adjustment.

1. There are four stabilizers and two cushions located on the underside of the treadmill as shown in drawing 1. These all need to sit firmly on the floor to prevent the treadmill from wobbling during use.

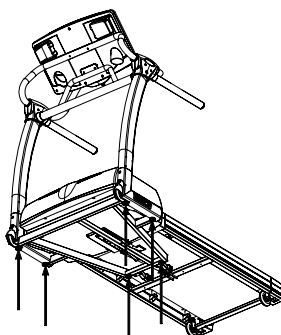

1. Four stabilizers towards the rear and two cushions at the front.

2. Inspect each side of the treadmill base frame. The treadmill should sit on the floor with all four stabilizers and both cushions resting firmly on the floor as shown in drawing 2. Shake the handlebars back and forth to check if they are resting firmly on the floor. If they are not, tilt the treadmill to one side to adjust the stabilizers as shown in drawing 3. Simply turn the stabilizers like a screw to adjust their heights. Repeat this until the treadmill sits firmly on the floor.

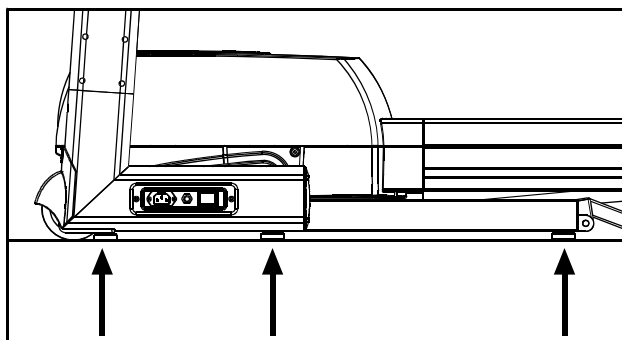

2. Check position of stabilizers and cushions.

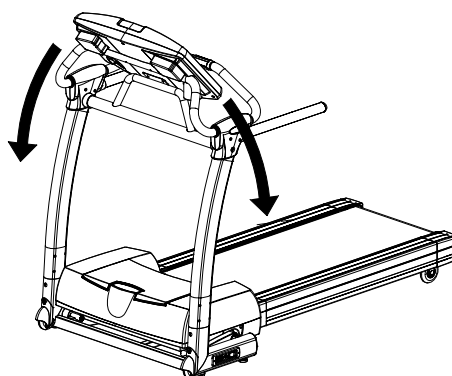

3. Tilt treadmill to access stabilizers.

FOLDING INSTRUCTIONS

How to fold up the treadmill:

Your treadmill can be folded up for space saving storage. To do this follow the instructions here:

1. To fold the deck you first need to bring the treadmill to the lowest incline level.

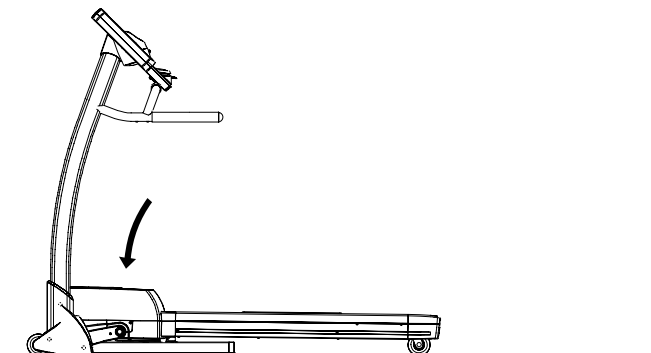

1. Lower deck to lowest incline level.

2. Lift the deck up from the rear of the treadmill and fold up until it locks in place. **TO PREVENT INJURY BE SURE YOU HAVE A FIRM HOLD WHEN RAISING THE DECK.**

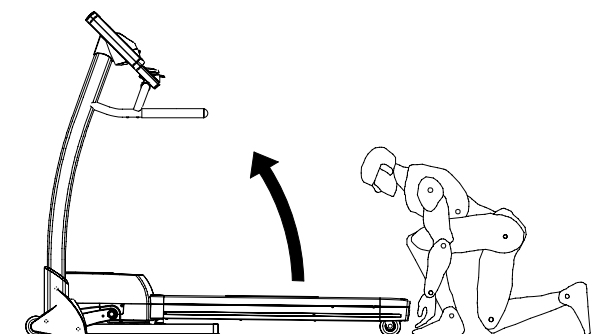

2. Lift the deck up from the rear.

3. You will hear a "click" sound as the lock engages.

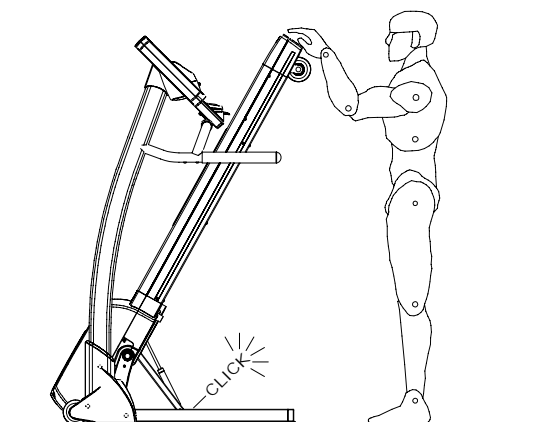

3. You will hear a "click" sound as the lock engages.

UNFOLDING INSTRUCTIONS**How to unfold the treadmill:**

To unfold the treadmill for use follow the instructions here:

1. Begin by standing behind and supporting the deck with your hands. Next release the lock with your foot by stepping on the release lever. **TO PREVENT INJURY BE SURE YOU HAVE A FIRM HOLD ON THE DECK BEFORE RELEASING THE LOCK.**

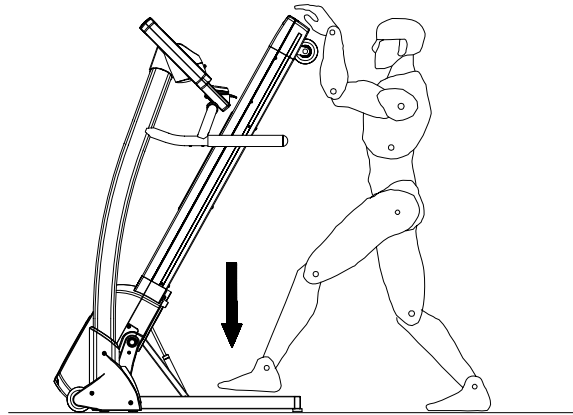

1. Release the lock with your foot by stepping on the release lever.

2. Slowly lower the deck until it rests securely on the ground.

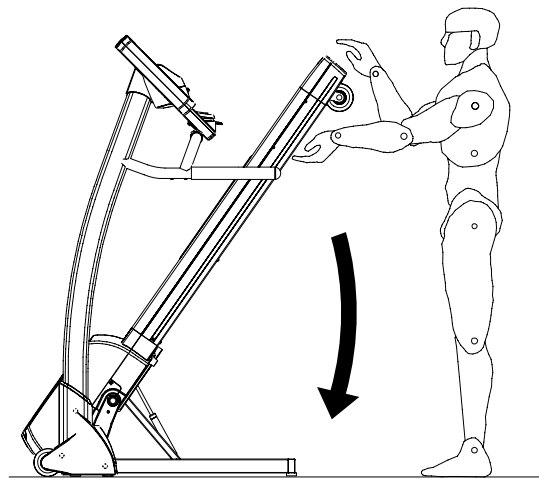

2. Lower the deck until it rests securely on the ground.

TRANSPORT INSTRUCTIONS**How to transport the treadmill:**

1. Start by first folding up the running deck as described on the FOLDING INSTRUCTIONS page in this manual. Then lift the treadmill a little bit up from the end of handlebars. You will see the Transportation Wheel Bracket spring out.

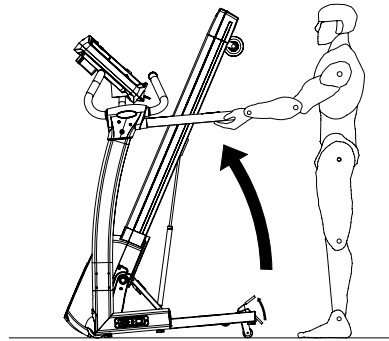

1. Fold up the running deck.

2. Stand behind the treadmill and grab the handlebars. Use the transport wheels to roll the treadmill to a desired position.

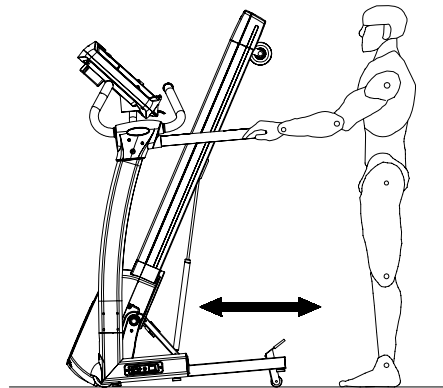

2. Grab the handlebars then push or pull the treadmill.

3. Once the treadmill is in place step on the Transportation Wheel Bracket to make the wheel back to place. Then follow the UNFOLDING and STABILIZER ADJUSTMENT instruction pages in this manual to level the frame to the floor.

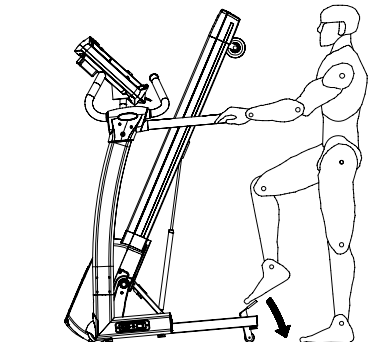

MAINTENANCE

HOW TO MAINTAIN YOUR TREADMILL:

Proper maintenance is very important to ensure your treadmill is always in top working condition. Improper maintenance could cause damage or shorten the life of your treadmill.

- **Important:** Never use abrasives or solvents to clean the treadmill. To prevent damage to the computer, keep liquids away and keep it out of direct sunlight.
- Inspect and tighten all parts of the treadmill regularly. Replace any worn parts immediately.

BELT ADJUSTMENT:

The running belt has been properly adjusted at the factory. However transportation, uneven flooring or other unpredicted reasons could cause the belt to shift off center resulting in the belt rubbing with the plastic side rail or end caps and possibly causing damage. To adjust the belt back to it's proper position please follow the directions below:

1. If your belt tends to walk to the right, rotate the right tension bolt clockwise. We recommend adjustments of 1/4 turn at a time, and follow with a test. If your belt continues to walk to the right, simply adjust the left belt tension bolt by turning it 1/4 turn counterclockwise, and follow with a test.
2. If your belt tends to walk to the left, rotate the left tension bolt clockwise 1/4 turn at a time, and follow with a test. If the belt continues to walk to the left, simply adjust the right tension bolt counterclockwise.
3. If your belt appears to be loose, simply tighten both bolts evenly 1/4 turn. If it appears tight, simply loosen both bolts evenly 1/4 turn.

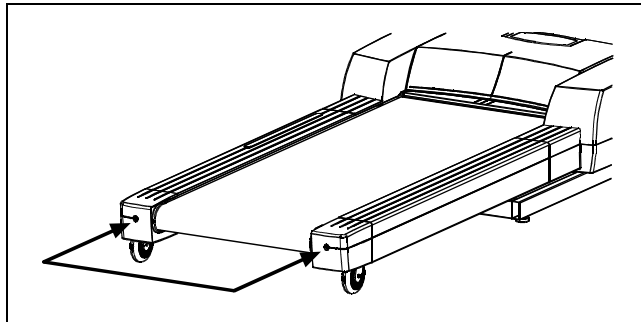

Right and left tension bolts are located at the rear of the treadmill.

DECK LUBRICATION:

The walking belt has been pre-lubricated at the factory. However, it is recommended that the walking board be checked periodically for lubrication to ensure optimal treadmill performance. Your treadmill should not have to be lubricated usually within the first year or 500 hours of use.

Every 30 days or 30 hours of operation lift the sides of the walking belt and feel the top surface of the walking board as far as you can reach. If you feel signs of silicone, no further lubrication is required. If it feels dry to the touch, follow the instructions below.

Please use a non-petroleum based silicone.

MAINTENANCE

To apply lubricant to the walking belt:

1. Position the walking belt so that the seam is located on top and in center of the walking board.
2. Insert the spray nozzle into the spray head of the lubricant can.
3. While lifting the side of the walking belt, position the spray nozzle between the walking belt and the board approximately 15 cm (6 inches) from the front of the treadmill. Apply the silicone spray to the walking board, moving from the front of the treadmill to the rear. Repeat this on the other side of the belt. Spray approximately 4 seconds on each side.
4. Allow the silicone to "set" for 1 minute before using the treadmill.

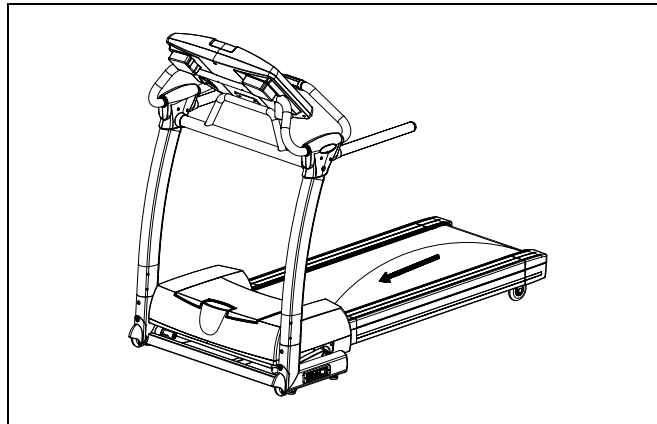

Spray lubricant from front to back.

CLEANING:

Routine cleaning of your treadmill will extend the product's life.

- **Warning:** To prevent electrical shock, be sure the power to the treadmill is OFF and the power cord is unplugged from the wall electrical outlet before attempting any cleaning or maintenance.
- **Important:** Never use abrasives or solvents to clean the treadmill. To prevent damage to the computer, keep liquids away and keep it out of direct sunlight.
- **After each workout:** Wipe off the console and other treadmill surfaces with a clean, water dampened soft cloth to remove excess perspiration.
- **Weekly:** Use of a treadmill mat is recommended for ease of cleaning. Dirt from your shoes contacts the belt and eventually makes it to underneath the treadmill. Vacuum underneath treadmill once a week.

WARRANTY

Warranty Coverage: Smooth Fitness, Inc. ("Smooth Fitness") warrants to the original purchaser that each new product to be free from defects in workmanship and material, under normal use and conditions.

Period of Coverage: The Warranty on this product runs from the date of your purchase for a period of LIFETIME on the frame, TEN (10) years on the motor, FIVE (5) years on the belt, deck and rollers, THREE (3) years on the electronics and ONE (1) year on labor. Smooth Fitness reserves the right to inspect damaged parts for misuse.

It is recommended that the Original Receipt be kept with the product manual.

Remedy Provided by Smooth Fitness: Smooth Fitness will provide a replacement part free of charge if a defect is found during the Warranty period. You must pay any charges for shipping and handling outside of the Continental United States and for labor. To obtain service call your local Smooth Retailer.

Any redemption may be by repair or replacement of the affected parts and/or product at the sole discretion of Smooth Fitness, by personnel approved by Smooth Fitness. If repairs are required, the unit will be repaired at the location of use or by return to the factory as deemed appropriate by Smooth Fitness.

Parts repaired or replaced pursuant to this Warranty shall be warranted for the unexpired portion of the Warranty applying to the original product. Any technical advice furnished before or after delivery in regard to the use or application of Smooth Fitness products is furnished without charge and on the basis that it represents Smooth Fitness' best judgment under the circumstances but that the advice is used at your sole risk.

Procedure for Obtaining Your Remedy Under This Warranty: To obtain service call your local Smooth Retailer. To help them assist you, please have the following information ready:

- Model name or number from the cover of the manual;
- Serial number located on the frame of the unit; and
- The part description and the order number.

Limitations on Warranty: This Warranty will only apply to the original end user. This Warranty does not cover any problems, damages or failures that are caused by accident, improper assembly, failure to observe cautionary labels on the product, failure to operate the product correctly, abuse or freight damage. Smooth Fitness does not warrant against any damage or defects that may result from repair or alterations made to the product by an unauthorized repair facility.

This Warranty shall terminate if you sell or otherwise transfer this product. This Warranty does not apply to any product shipped or handled outside of the United States or Canada. This Warranty does not apply if the product is used for rental or commercial use. Consequential and incidental damages are not recoverable under this Warranty. (Some states do not allow the exclusion or limitation of incidental or consequential damages, so the above limitation or exclusion may not apply to you.)

THIS WARRANTY IS EXPRESSLY IN LIEU OF ALL OTHER EXPRESS WARRANTIES. ALL IMPLIED WARRANTIES, INCLUDING WARRANTIES OF MERCHANTABILITY OR FITNESS FOR ANY PARTICULAR PURPOSE, ARE LIMITED IN DURATION TO ONE (1) YEAR FROM THE EFFECTIVE DATE OF THIS WARRANTY. SMOOTH FITNESS IS NOT LIABLE FOR CONSEQUENTIAL OR INCIDENTAL DAMAGES RESULTING FROM ANY DEFECT IN PARTS NOR FOR ANY BREACH OF EXPRESS OR IMPLIED WARRANTIES. SMOOTH FITNESS' SOLE LIABILITY UNDER THIS WARRANTY IS LIMITED TO THE TERMS DESCRIBED IN THIS FORM. THIS WARRANTY GIVES YOU SPECIFIC LEGAL RIGHTS, AND YOU MAY ALSO HAVE OTHER RIGHTS WHICH VARY FROM STATE TO STATE.

For assistance with assembly or to order replacement parts, simply call your local Smooth Retailer. To help them assist you, please have the following information ready:

- Model name or number from the cover of the manual;
- Serial number located on the frame of the unit; and
- The part description and order number.

IMPORTANT STEPS

Warning:

Before using this product, please consult your personal physician for a complete physical examination. Frequent and strenuous exercise should be approved by your doctor first. If any discomfort should result from your use of this product, stop exercising and consult your doctor. Proper usage of this product is essential. Please read your manual carefully before exercising.

Please keep all children away from the equipment during use and when equipment is unattended.

Always wear appropriate clothing, including athletic shoes, when exercising. Do not wear loose clothing that could become caught during exercising.

Make sure that all bolts and nuts are tightened when equipment is in use. Periodic maintenance is required on all exercise equipment to keep it in good condition.

Before beginning:

How you begin your exercise program depends on your physical condition. If you have been inactive for several years, or are severely overweight, you must start slowly and increase your time gradually, a few minutes per week.

Initially you may be able to exercise only for a few minutes in your target heart rate zone. However, your aerobic fitness will improve over the next six to eight weeks. Don't be discouraged if it takes longer. It's important to work at your own pace. Ultimately, you'll be able to exercise continuously for 30 minutes. And the better your aerobic fitness, the harder you will have to work to stay in your target heart rate zone. But remember these essentials:

- Contact your physician before starting a workout or training program. Have your doctor review your training and diet programs to advise you of a workout routine you should adopt.
- Begin your training program slowly with realistic goals that have been set by you and your doctor.
- Supplement your program with some type of aerobic exercise such as walking, jogging, swimming, dancing and/or bicycling. Monitor your pulse frequently. If you do not have an electronic heart rate monitor, have your physician show you the proper way to manually check your pulse by using your wrist or neck. Establish your target heart rate based on your age and condition.
- Drink plenty of fluids during the course of your routine. You must replace the water content lost from excessive exercising to avoid dehydration. Avoid drinking large amounts of cold liquids. Fluids should be at room temperature when consumed.

TARGET HEART RATE

Finding your pulse:

To make sure your heart is beating in its target zone, you'll need to know how to monitor your heart rate. The easiest way is to feel the pulse in the carotid artery on either side of your neck, between the windpipe and the large neck muscles. Count the number of beats in ten seconds, and then multiply that number by six. This gives you the number of beats per minute.

How fast should your heart beat during aerobic exercise? Fast enough to reach and stay in its "target zone," a range of beats per minute that is largely determined by your age and physical condition. To determine your target zone, consult the chart we have provided.

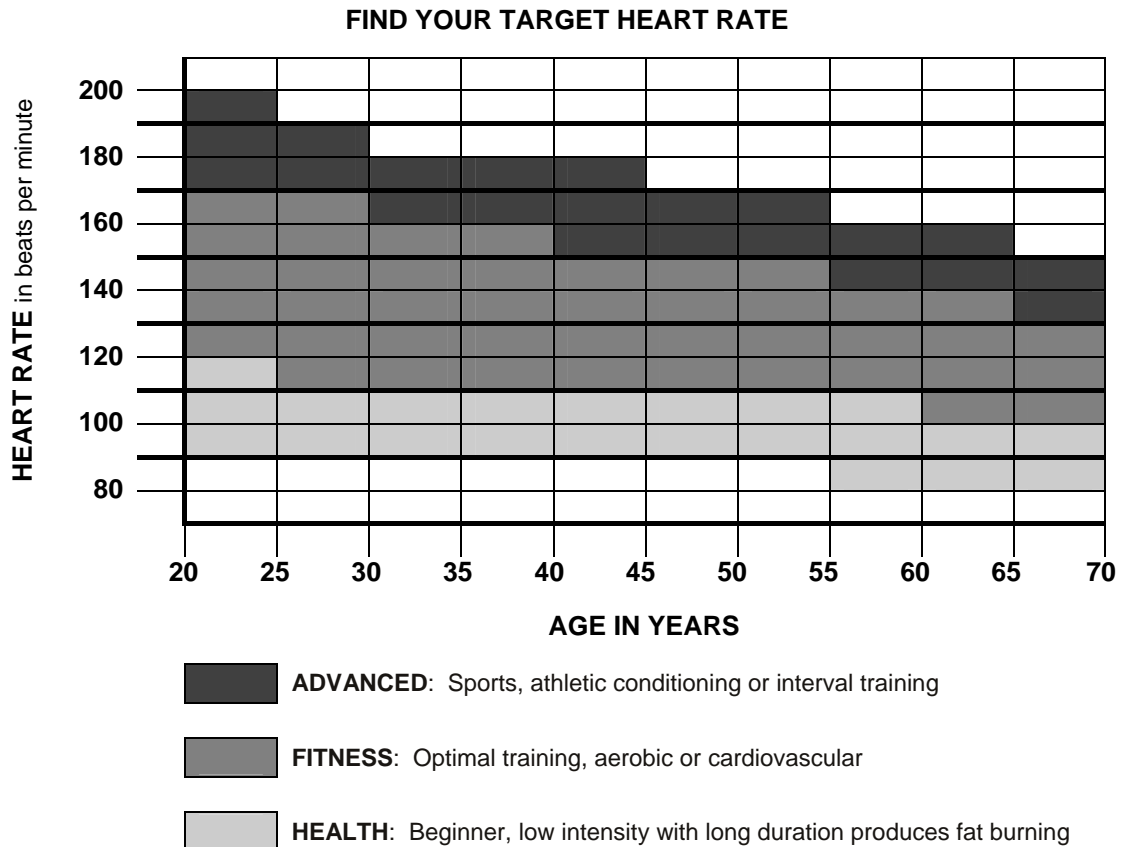

Aerobic exercise:

Is any sustained activity that sends oxygen to your muscles via your heart and lungs. It will improve the fitness of your lungs and heart: your body's most important muscle. Aerobic fitness is promoted by any activity that uses your large muscle groups - arms, legs or buttocks, for example. Your heart beats quickly and you breathe deeply. An aerobic exercise should be part of your entire exercise routine.

MUSCLE CHART**Targeted muscle groups:**

The exercise routine that is performed on this product will develop primarily lower body muscle groups. These muscle groups are shown in gray color on the chart below.

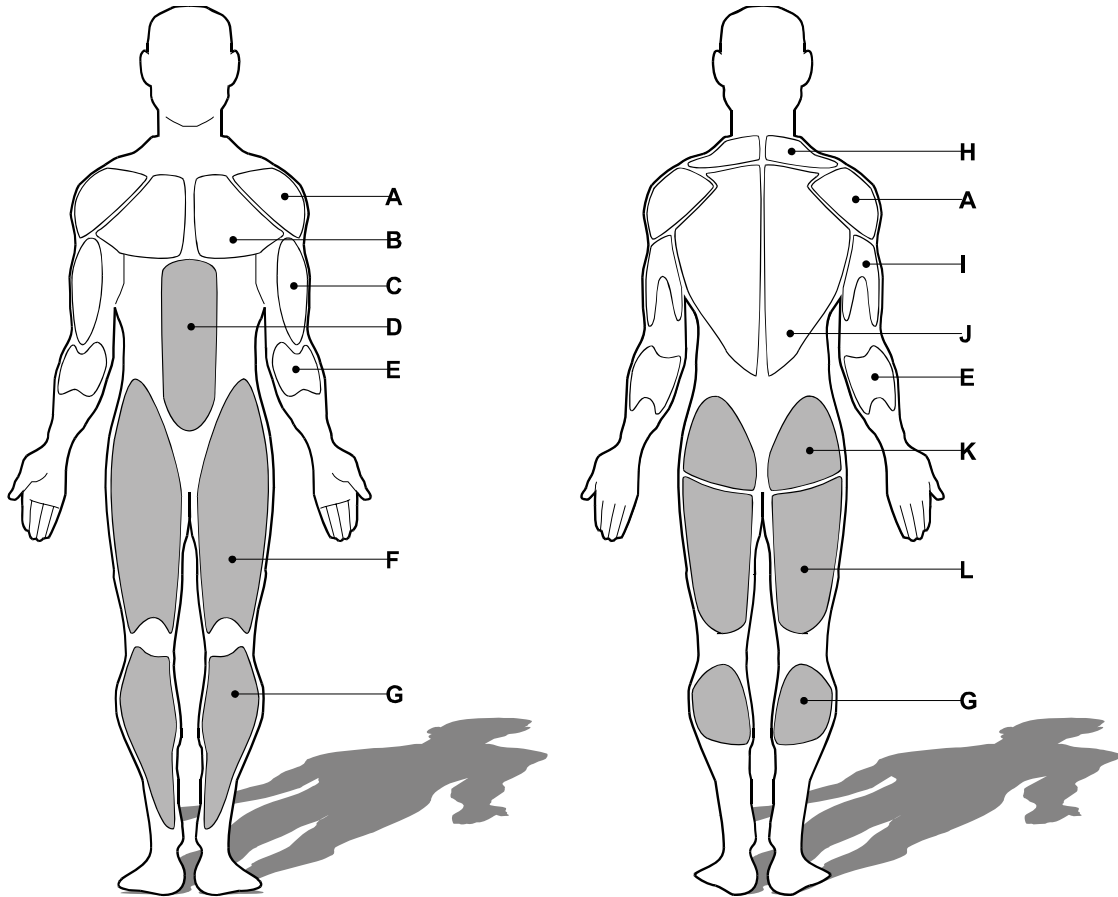

Shoulder muscles	<input type="checkbox"/> A	<input type="checkbox"/> B	Pectoral muscles
Bicep muscle	<input type="checkbox"/> C	<input type="checkbox"/> D	Abdominal muscles
Forearm muscles	<input type="checkbox"/> E	<input type="checkbox"/> F	Quadricep muscles
Calf muscles	<input type="checkbox"/> G	<input type="checkbox"/> H	Trapezius muscles
Tricep muscles	<input type="checkbox"/> I	<input type="checkbox"/> J	Back muscles
Gluteal muscles	<input type="checkbox"/> K	<input type="checkbox"/> L	Hamstring muscles

STRETCHING ROUTINE

Warm up and cool down:

A successful exercise program consists of a warm-up, aerobic exercise, and a cool-down. Do the entire program at least two or three times a week, resting for a day between workouts. After several months, you can increase your workouts to four or five times per week.

Warming up is an important part of your workout, and should begin every session. It prepares your body for more strenuous exercise by heating up and stretching out your muscles, increasing your circulation and pulse rate, and delivering more oxygen to your muscles. At the end of your workout, repeat these exercises to reduce sore muscle problems. We suggest the warm-up and cool-down exercises on the following pages:

Toe Touch:

Slowly bend forward from your waist, letting your back and shoulders relax as you stretch toward your toes. Reach down as far as you can and hold for 15 counts.

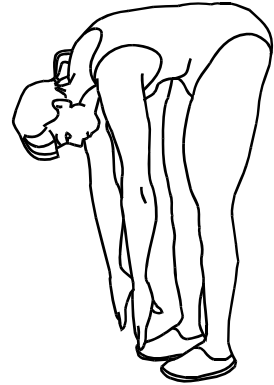

Shoulder Lift:

Lift your right shoulder up toward your ear for one count. Then lift your left shoulder up for one count as you lower your right shoulder.



Head Roll:

Rotate your head to the right for one count, feeling the stretch up the left side of your neck. Next, rotate your head back for one count, stretching your chin to the ceiling and letting your mouth open. Rotate your head to the left for one count, and finally, drop your head to your chest for one count.



STRETCHING ROUTINE**Hamstring Stretch:**

Sit with your right leg extended. Rest the sole of your left foot against your right inner thigh. Stretch toward your toe as far as possible. Hold for 15 counts. Relax and then repeat with left leg extended.

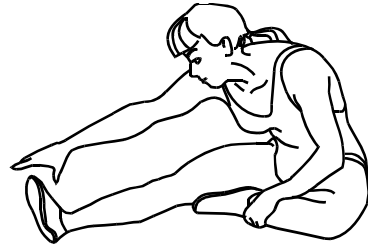
**Inner Thigh Stretch:**

Sit with the soles of your feet together with your knees pointing outward. Pull your feet as close into your groin as possible. Gently push your knees towards the floor. Hold for 15 counts.

**Side Stretch:**

Open your arms to the side and continue lifting them until they are over your head. Reach your right arm as far upward toward the ceiling as you can for one count. Feel the stretch up your right side. Repeat this action with your left arm.

**Calf-Achilles Stretch:**

Lean against a wall with your left leg in front of the right and your arms forward. Keep your right leg straight and the left foot on the floor; then bend the left leg and lean forward by moving your hips toward the wall. Hold, and then repeat on the other side for 15 counts.

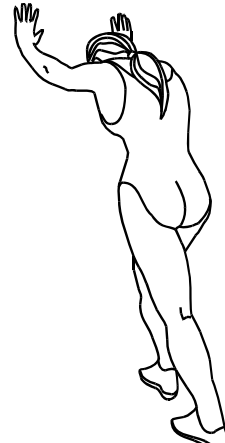

TROUBLESHOOTING

Troubleshooting

NOTE: Do not touch any internal electric wires without consulting the manufacturer.

Treadmill will not start:

1. Make sure the power cord is plugged into a surge protector, the surge protector is plugged into a properly grounded outlet and the surge protector is turned on (refer to the Power Requirements section in this manual).
2. Check the circuit breaker reset switch located on the front of the treadmill. Turn the power off, wait 5 minutes then press the rest switch.
3. Check the house electrical breaker box and the circuit breaker for the room the treadmill is located in. If it has tripped, reset or have an electrician replace the breaker in home.
4. Have an electrician check for inadequate voltage at the outlet.

Treadmill loses power during use:

1. Check the circuit breaker reset switch located on the front of the treadmill. Turn the power off, wait 5 minutes then press the rest switch.
If the treadmill still will not operate, please call Technical service at 1.888.800.1167.
2. Check the house electrical breaker box and the circuit breaker for the room the treadmill is located in. If it has tripped, reset or have an electrician replace the breaker in home.

Treadmill walking belt slows during use:

1. Check to make sure the treadmill is securely plugged into an UL-listed surge protector, rated at 15 amps, with a 14-gauge cord of five feet or less and the surge protector is securely plugged into the outlet. If the treadmill still will not operate, please call Technical service at 1.888.800.1167.

Treadmill walking belt slips or is not centered on rear roller:

Refer to the Belt Adjustment section of this manual. If you require additional assistance please call Technical service at 1.888.800.1167.



Smooth Fitness
112 Gaither Drive
Mt. Laurel, NJ 08054

Toll Free Customer Service:
1.888.800.1167

Website:
www.SmoothFitness.com